

# 3-SERIES

TW 50-3 - 5.0m (16'4") reach

## EXTRA FOR THIS SERIES

Low pressure hydraulic control option

Sliding mount, direct drive flailhead

## EXTRA FOR THIS SERIES

Parallel Arm Geometry



## EXTRA FOR THIS SERIES

3pt linkage mounting with heavy duty stabiliser

Large 140ltr oil capacity

50hp hydraulic system

*A precise, productive mid-range machine, the 3-Series has been created especially for farmers and small-scale contractors.*

TWOSE

# 3-SERIES REACH ARM



# PERFORMANCE AND VALUE

Featuring 5.0m reach, 50hp hydraulics, and parallel arm geometry, Twose's TW 50-3 is ideal for those seeking a productive and dependable machine that offers outstanding value.

With a choice of control systems, including Twose's proven low pressure hydraulic proportional joystick, the TW 50-3 is intuitive and easy to master and comes with a wide range of working attachments from Cutterbars to Sawheads.



Featuring Low Pressure hydraulic controls. See page 19 for details.

3-SERIES REACH ARM	
Specification	TW 50-3
HP	50hp
Reach	5.0m
Slew	—
Angle Float	■
Lift Float	□
Mounting	3pt
Oil Cooler	□
Road Lighting	□
Weight	1126kg
Oil Tank	140ltr
Safety Breakaway	Mechanical
ARM SETS	
Standard	—
Parallel Arm Geometry	■
Telescopic	—
VFR	—
CONTROLS	
Proportional Cable	■
Proportional Low Pressure	□
FLAILHEADS	
1.0m Compact Flailhead	—
1.2m Compact Flailhead	—
1.2m Sliding Mount, Direct Drive Flailhead	■
1.5m Sliding Mount, Direct Drive Flailhead	—
REQUIREMENTS	
Minimum tractor weight	2250kg
Minimum tractor horsepower	60hp

■ Standard Equipment □ Optional Equipment — Not available

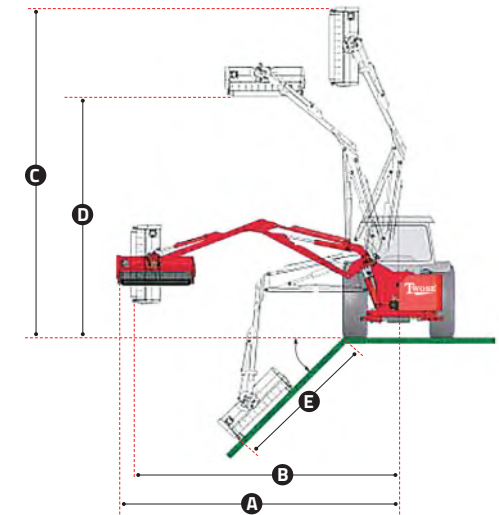

Note - Visual for illustration only

## REACH DIMENSIONS

MODEL	A	B	C	D	E
TW 50-3	5.0m	4.8m	6.0m	4.6m	3.1m

### SPECIFICATION

- 5.0m reach
- 3-point linkage
- 50hp hydraulics

### ARMSETS

- Standard straight arm
- Parallel arm geometry

### CONTROLS

- Proportional cable controls
- Proportional low pressure hydraulic controls

### KEY FEATURES

- 240-degree head rotation
- Dual direction cutting
- Mechanical breakaway protection
- 140-litre oil tank capacity
- Cast iron pumps and motor
- Angle float
- Road lighting (optional)
- Lift float (optional)

### FLAILHEADS

- 1.2m sliding mount direct drive flailhead

### ATTACHMENTS

- Sawheads
- Cutterbars

### TRACTOR REQUIREMENTS

- 60hp, 2,250kg