

5-SERIES

TW 57-5 - 5.70m (18'10") reach
TW 60-5 - 6.00m (19'8") reach
TW 65-5 - 6.50m (21'4") reach
TW 67T-5 - 6.70m (22'2") reach

EXTRA FOR THIS SERIES

Electric Proportional control (EPP) option



Parallel Arm Geometry

Hydraulic Slew

EXTRA FOR THIS SERIES

Hydraulic oil cooler with auto reversing fan

Twose's 5-Series machines come with a productive specification and a suite of advanced features that make them an ideal tool for professional contractors.

3pt linkage mounting with heavy duty stabiliser

EXTRA FOR THIS SERIES

High capacity 200ltr oil reservoir

EXTRA FOR THIS SERIES

65hp hydraulic system

EXTRA FOR THIS SERIES

Axle mounting option

TWOSE

5-SERIES REACH ARM



PURPOSE-BUILT FOR PROFESSIONALS

Twose's flagship 5-Series offers four different reach options from 5.7 to 6.7m, 65hp high-performance hydraulics, and a choice of advanced control systems.

Three different armsets are available including: Standard; Telescopic – for adding or retracting up to 1.0m of extra reach on demand; and Cranked Forward Reach (CFR) – enhancing comfort, visibility and reducing fatigue.



Oil cooler fitted as standard. See page 20 for details

5-SERIES REACH ARM

Specification	TW 57-5	TW 60-5	TW 65-5	TW 67T-5
HP	65hp	65hp	65hp	65hp
Reach	5.7m	6.0m	6.5m	6.7m
Slew	■	■	■	■
Angle Float	■	■	■	■
Lift Float	□	□	□	□
Mounting	3pt	3pt	3pt	3pt
Oil Cooler	■	■	■	■
Road Lighting	□	□	□	□
Weight	1470kg	1482kg	1498kg	1611kg
Oil Tank	200ltr	200ltr	200ltr	200ltr
Safety Breakaway	Hydraulic	Hydraulic	Hydraulic	Hydraulic
Axle Mounting	□	□	□	□
ARM SETS				
Standard	—	—	—	—
Parallel Arm Geometry	■	■	■	■
Telescopic	—	—	—	■
CFR	□	—	□	—
CONTROLS				
Proportional Cable	□	□	□	—
Proportional Low Pressure	□	□	□	□
Proportional Electric (EPP)	□	□	□	□
FLAILHEADS				
1.0m Compact Flailhead	—	—	—	—
1.2m Compact Flailhead	—	—	—	—
1.2m Centre Mount, Belt Drive Flailhead	—	—	—	—
1.2m Sliding Mount, Belt Drive Flailhead	■	■	■	■
1.5m Sliding Mount, Belt Drive Flailhead	□	□	□	—
REQUIREMENTS				
Minimum tractor weight	3000kg	3000kg	3000kg	3750kg
Minimum tractor horsepower	70hp	70hp	70hp	100hp

■ Standard Equipment □ Optional Equipment — Not available

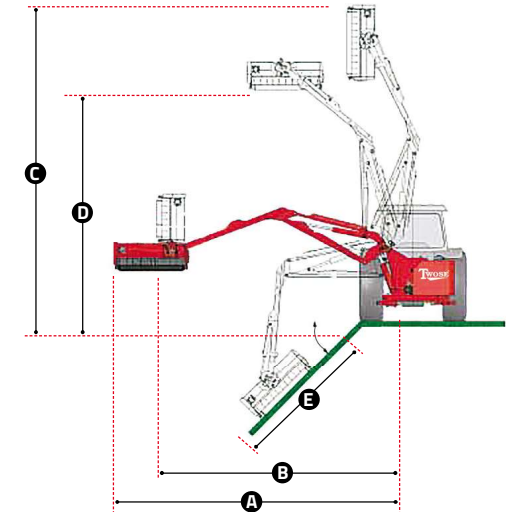

Note - Visual for illustration only

REACH DIMENSIONS

MODEL	A	B	C	D	E
TW 57-5	5.7m	5.4m	6.6m	5.2m	3.7m
TW 60-5	6.0m	5.7m	6.9m	5.2m	3.8m
TW 65-5	6.5m	6.2m	7.2m	5.5m	4.2m
TW 67T-5	6.7m	6.4m	7.5m	5.8m	4.5m

* Dimensions based on 1.2m Sliding Mount Flailhead

SPECIFICATION

- 5.7m, 6.0m, 6.5m & 6.7m reach
- 3-point linkage
- 65hp hydraulics

ARMSETS

- Standard (5.7m, 6.0m & 6.5m)
- Parallel arm geometry (all models)
- Telescopic (6.7m)
- Cranked Forward Reach (CFR) (5.7m & 6.5m)

CONTROLS

- Proportional cable controls
- Proportional low pressure hydraulic controls
- Proportional electric controls (EPP)

KEY FEATURES

- Slide-mount flailhead
- 240-degree head rotation
- Dual direction cutting
- Hydraulic slew
- Hydraulic breakaway protection
- 200-litre oil tank capacity
- Cast iron pumps and motor
- Angle float
- Road lighting (optional)
- Lift float (optional)
- Axle mounting (optional)
- Oil cooler kit

FLAILHEADS

- 1.2m sliding mount belt drive flailhead
- 1.5m sliding mount belt drive flailhead (not available with TW67T-5 model)

ATTACHMENTS

- Sawheads
- Cutterbars

TRACTOR REQUIREMENTS

- From 70hp, 3,000kg