

2-SERIES

TW 48-2 - 4.8m (15'7") reach

EXTRA FOR THIS SERIES

Centre mount,
belt drive flailhead



Standard straight
arm configuration

3pt linkage mounting
with chain stabiliser

*Affordable and accessible,
the 2-Series is for farmers
seeking a robust, value-
for-money reach arm that's
equally adept at hedge-
cutting and verge-mowing.*

EXTRA FOR THIS SERIES

Large 140ltr oil capacity

EXTRA FOR THIS SERIES

45hp hydraulic system

TWOSE

2-SERIES REACH ARM



EASY AND AFFORDABLE

Twose's economy series has been designed to deliver a big performance at a small price with 4.8m reach, solid build quality, and 45hp hydraulics.

Created for farmers seeking a simple, straightforward machine, the TW 48-2 features the proven precision of cable controls, as well as cast iron pumps and mechanical safety breakaway for durability, while the new optional high-visibility LED road lights enable operators to work safer and longer.



Featuring Low Pressure hydraulic controls. See page 19 for details

2-SERIES REACH ARM	
Specification	TW 48-2
HP	45hp
Reach	4.8m
Slew	—
Angle Float	■
Lift Float	□
Mounting	3pt
Oil Cooler	—
Road Lighting	□
Weight	1013kg
Oil Tank	140ltr
Safety Breakaway	Mechanical
ARM SETS	
Standard	■
Parallel Arm Geometry	—
Telescopic	—
CFR	—
CONTROLS	
Proportional Cable	■
Proportional Low Pressure	—
Proportional Electric (EPP)	—
FLAILHEADS	
1.0m Compact Flailhead	—
1.2m Compact Flailhead	—
1.2m Centre Mount, Belt Drive Flailhead	■
1.2m Sliding Mount, Belt Drive Flailhead	—
1.5m Sliding Mount, Belt Drive Flailhead	—
REQUIREMENTS	
Minimum tractor weight	2250kg
Minimum tractor horsepower	55hp

■ Standard Equipment □ Optional Equipment — Not available

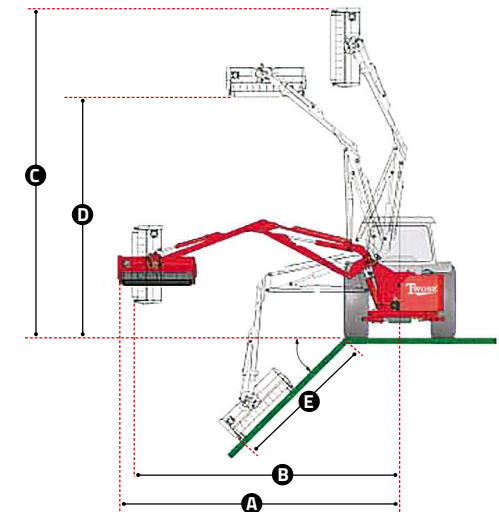

Note - Visual for illustration only

REACH DIMENSIONS

MODEL	A	B	C	D	E
TW 48-2	4.8m	4.5m	5.6m	4.2m	3.0m

SPECIFICATION

- 4.8m reach
- 3-point linkage
- 45hp hydraulics

ARMSETS

- Standard straight arm

CONTROLS

- Proportional cable controls

KEY FEATURES

- Centre mount flailhead
- 240-degree head rotation
- Dual direction cutting
- Mechanical breakaway protection
- 140-litre oil tank capacity
- Cast iron pumps and motor
- Angle float
- Road lighting (optional)
- Lift float (optional)

FLAILHEADS

- 1.2m centre mount belt drive flailhead

ATTACHMENTS

- Sawheads
- Cutterbars

TRACTOR REQUIREMENTS

- 55hp, 2,250kg