

TC Range of Hedge and Verge Cutters

- 5.25m (17ft 6in) reach
- Parallel arm geometry
- 1.2m cut flailhead (belt drive)
- Totally independent hydraulics
- 3-point linkage mounted (Cat II)
- Cast iron pumps and motor
- Powerslew and hydraulic breakaway
- Cable or proportional controls
- 240° head rotation
- 200 litre capacity
- Head float
- Dual direction flail rotation
- Cab safety guard kit
- Heavy duty bar stabiliser kit
- Oil included
- Minimum tractor requirements TC526

65hp, 3000kg.



Controls



Cable Controls



Low Pressure Hydraulic Proportional Joystick

Cutting Dimensions

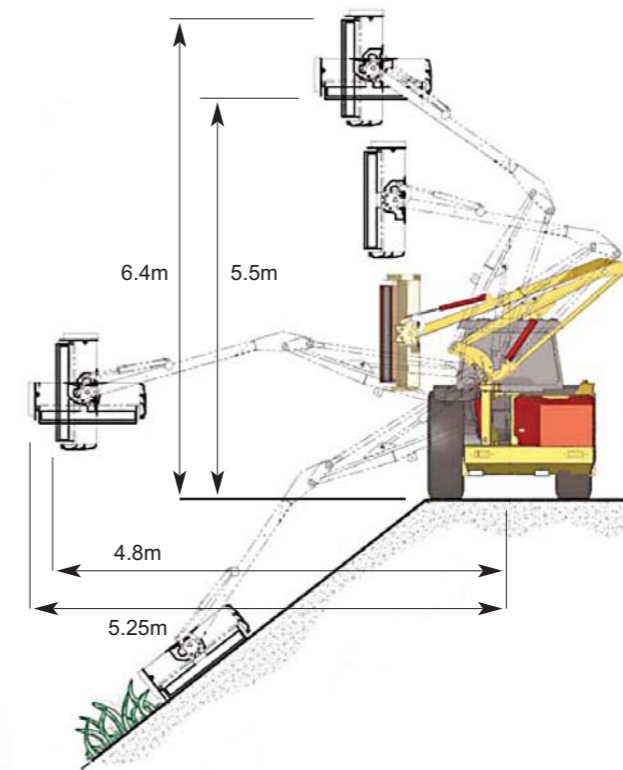

Double Skin Cutter Head

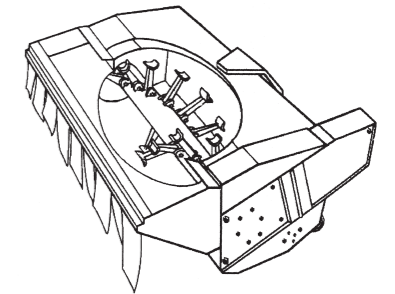

- Double skin for greater strength and longer working life.
- Drive line contained within width of skid for a cleaner cut and better manoeuvrability.
- Simple belt adjustment
- Quick fit heavy duty rotor takes 5 types of flail
- Heavy braced end panels
- Adjustable heavy duty roller
- Skid wrapped around panel for greater protection
- Nose guard with barbed wire trap and heavy duty curtain
- Choice of flails

Machine Type	TC526
Reach (m / ft, ins)	5.25 / 17'6"
Cutting width (m)	1.2
Minimum tractor power (hp)	65
Left or right cut	Optional
Parallel arm geometry	Standard
Sprung top link	Standard
Powerslew & hydraulic breakaway	Standard
Flail cutting reversible by cable control	Standard
Fully Independent Hydraulics	Standard
Cable controls	Standard
Low pressure hydraulic joystick	Optional
Flotation	
Head flotation	Standard
Boom flotation	Optional
Options	
Rear lights	Optional
High power	Optional
Quick hitch	Optional



Heavy Duty Reversible Lump Flail for hedging and occasional mowing. Fitted as standard unless stated



Heavy Duty Grass and hedging flail. Cuts in one direction



Back to Back reversible flail for grass cutting



Cast Boot Flail and shackle for mowing or hedging. Cuts in one direction only



Back to Back reversible flail and shackle for grass cutting